

CORR - DEFENSE

HAND HELD UNIT HHU

High Resolution Multifunction

The Corr-defense HHU represents a cutting-edge, portable corrosion monitoring device, boasting high resolution and battery-powered functionality. It excels in reading various electrical resistance (ER), linear polarization resistance (LPR), and galvanic probes.

Operating the unit is a breeze, thanks to its integrated menu-driven screen, facilitating swift measurements of metal loss for ER probes, corrosion rate for LPR probes, and current or potential for galvanic probes.

With a generous internal memory capacity of up to 7,200 data points and the ability to store up to 100 probe tags, users can easily manage and organize their data. Transferring data to a PC equipped with Corr-defense Software (CDAS) is seamless via the RS-232 Serial ASCII to USB connection. Once transferred, the accompanying software empowers users to analyze data, visualize metal loss trends, and calculate corrosion rates. Furthermore, data can be exported in CSV format for compatibility with Excel and other applications.



CD-ER/LPR HANDHELD UNIT

USE WITH ER, LPR AND GALVANIC PROBES

UP TO 100 PROBE TAGS AND 7,200 DATA POINTS CAN BE STORED

CHANGE PROBE TECHNOLOGY WITHOUT CHANGING HARDWARE

EASY TO REPLACE LITHIUM BATTERY PACK

DIRECT PROBE READINGS AND DCU MEASUREMENT DOWNLOADS

Technical specifications

Probe Type	Electrical Resistance (ER) Linear Polarization Resistance (LPR) Galvanic - Potential
Resolution	20 bits
Memory	7,200 Readings / 100 Probe Tags
Temperature Range	-20 °C to + 70 °C (-4 °F -- 158 °F)
Power Supply	Lithium Battery Pack (7.2V 5Ah)
Battery Life	2-3 Years
IECEx	Ex ia IIC T4 Ga/Gb
ATEX	Ex II ½ G Ex ia IIC T4 Ga/Gb
Ingress Protection	IP66
Communication	RS-232 Serial ASCII Bus 9600, 8, N, 1
Weight	0.4 kg (0.9 lb)
Dimensions	106 mm x 224 mm x 59 mm

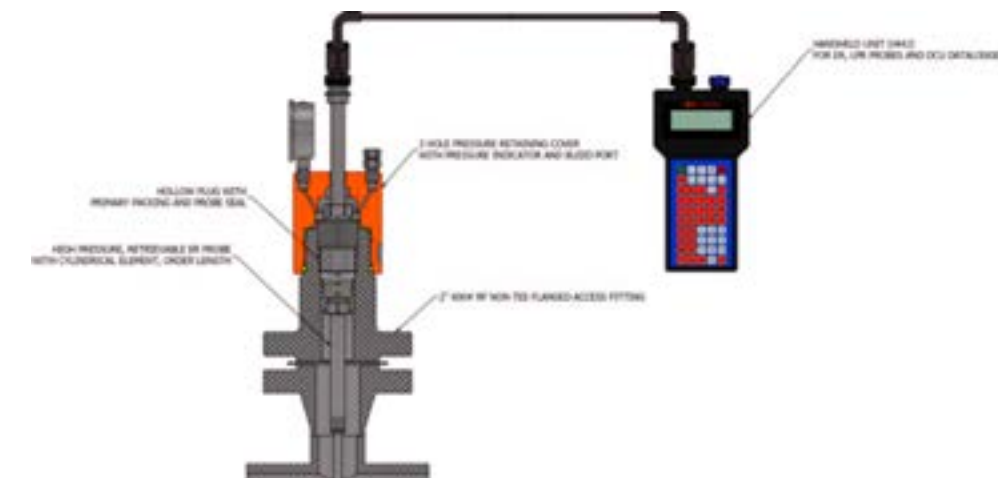

Part Numbering

CD-HHU	Hand Held Unit
CD-HHU-CBL	Hand Held Spare Cable
CD-HHU/DCU-TP	Hand Held/DCU Test Probe
CD-HHU/DCU-BATT	Hand Held/DCU Battery Pack

HR ER PROBES

CD High Resolution ER (Electrical Resistance) Corrosion Probes

Early detection of corrosion plays a pivotal role in establishing and fortifying a robust corrosion control program. Corr-defense's HR ER probes are meticulously crafted and designed to seamlessly integrate with High-Resolution Instrumentation, providing a highly sensitive method for identifying corrosion and erosion occurrences. These probes vigilantly monitor subtle changes in the electrical resistance of metal elements directly exposed to the process.

Operating on a well-established industry technique, HR ER probes detect corrosion or erosion by noting the increase in electrical resistance as the cross-sectional area of the metal element diminishes. Corr-defense HR ER probes feature a reference element constructed from the same material as the measurement element. Encased within the probe body, the reference element remains shielded from the process, facilitating auto-compensation for variations in electrical resistance caused by factors like temperature.



Unlike some alternative technologies, Corr-defense HR ER probes operate independently of process properties, making them suitable for deployment in virtually any environment.

Integration of Corr-defense HR ER probes and High-Resolution instrumentation into integrity management programs enables swift and reliable detection of alterations in corrosion/erosion rates. This empowers operators, integrity, and maintenance teams to optimize corrosion control measures, bolster safety protocols, and extend asset lifespans. Corr-defense offers

ER probes in various configurations to suit diverse monitoring locations and processes. Tubular element probes, renowned for durability and longevity, excel in center-of-line monitoring. Flush probes, designed to align with the pipe wall, are ideal for monitoring top and bottom line areas susceptible to localized corrosion. With a range of mounting options available for both high- and low-pressure systems, many of these probes are retrievable for maintenance and replacement under standard operating conditions using Corr-defense retrieval equipment.



Key Features

- Multiple Mounting Options (High and Low Pressure).
- Ideal for High Pressure 6K PSI and High Temperature Applications.
- Shields available for High Velocity Flow.
- Flush Probe Element available for Bottom of the Line/Pig-able Lines.
- Cylindrical and Flush elements available in a range of materials required and different Probe Spans to suit.

Sample Part Numbering

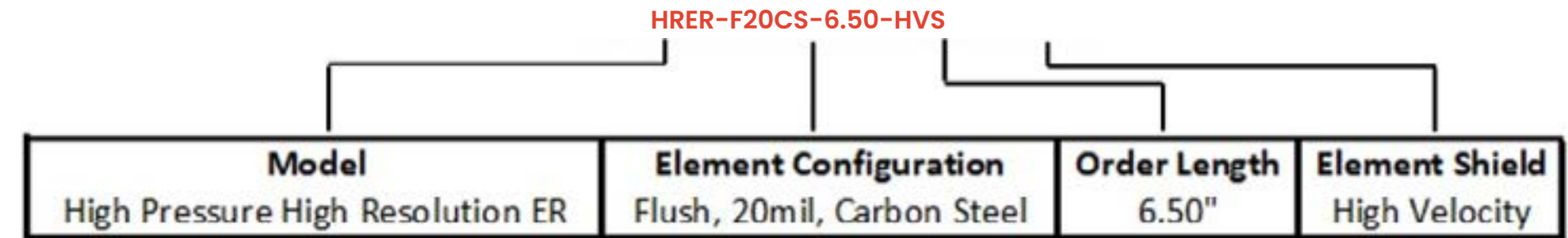



HP Mechanical Access Fitting System

High Pressure Access Systems

Corr-defense presents an extensive selection of high-pressure access fitting assemblies meticulously crafted for the installation of intrusive corrosion monitoring and chemical injection devices. Our product line encompasses both mechanical and hydraulic systems, with a focus on the 2" models.

The Corr-defense 2" Mechanical Access and Retrieval System provides a compre-

hensive solution for the secure installation and retrieval of probes and coupons from high-pressure piping and vessels. Engineered to withstand pressures of up to 6,000 PSI (414 Bar) and temperatures of up to 204 °C (400 °F), this system ensures reliability in demanding environments. Moreover, Corr-defense offers specialized fittings tailored to accommodate pressures of up to 10,000 PSI (689 Bar).

Our 2" Mechanical Access products seamlessly integrate with industry-standard offerings from other vendors, guaranteeing compatibility and ease of interchangeability.

The Corr-defense 2" Mechanical Access and Retrieval system comprises the following components:

- High pressure mechanical access fitting
- Mechanical hollow and solid plugs
- Heavy duty pressure retaining covers (up to 10,000psi/690 bar)
- Mechanical retrieval tool and service valve (see separate brochure and data sheet)

Mechanical Access Fittings

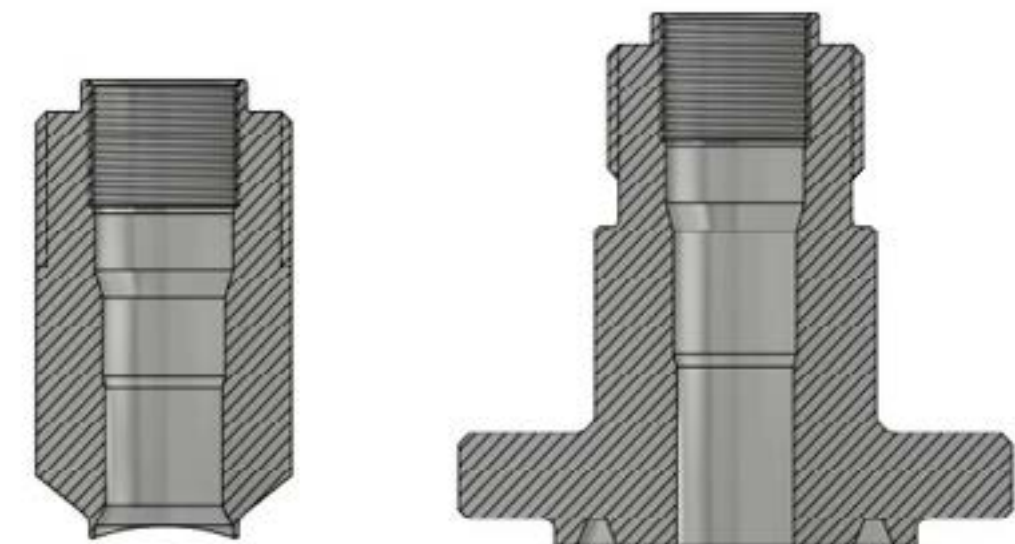

Our Mechanical Access Fitting comes in both flareweld and flanged variations, meticulously crafted from standard materials such as ASTM A105, ASTM A350 Gr.LF2, and Duplex steel. However, upon request, alternative versions (like HUB fittings) and materials are also available.

These Mechanical Access Fittings strictly adhere to NACE MR0175 requirements for sour service. NORSOK specifications can be provided upon request, and compliance with PED standards is also an option.

Corr-defense also offers 2" Mechanical Access Systems tailored for injection and sampling applications. For more detailed information, please refer to the relevant datasheets or contact a Corr-defense specialist for further assistance.

High Pressure Access Systems

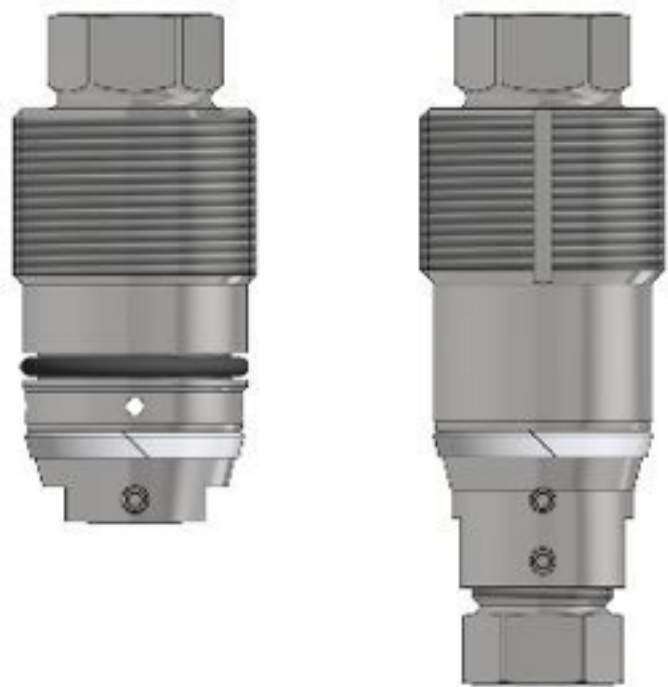

The Hollow or Solid Plug plays a critical role in providing a pressure seal within the access fitting and serves as the carrier for corrosion monitoring devices such as probes or coupon holders. Typically, the primary packing is constructed from PTFE (15% glass filled), though alternative materials, including metal seals suitable for high-temperature environments, are also available. The mechanical solid plug features an O-ring, which must be carefully chosen based on the specific application requirements.

Mechanical hollow plugs are utilized for online probes like ER (Electric Resistance) and LPR (Linear Polarization Resistance) probes, while mechanical solid plugs are employed for passive monitoring devices such as weight loss coupons, bio coupons, and injection/sampling equipment.

Corr-defense offers Hollow and Solid plugs in 316 SS and Duplex as standard options. Additionally, plug threads are coated, and Corr-defense experts can provide assistance in material selection to minimize or eliminate galling issues.

For high-velocity applications, special plug designs are tailored based on findings from wake frequency calculations. For further details, it's recommended to consult with Corr-defense.

The Mechanical Access Fitting features an ACME threaded outlet designed to mate with the service valve of the mechanical retrieval tool system. It establishes a threaded connection with the hollow/solid plug. Internal ACME threaded fittings are also available. To maintain the integrity of the external ACME threaded section, a protective cover is utilized.

Mechanical Access Fitting Covers

The Pressure Retaining Cover provides secondary isolation capabilities of up to 10,000 PSI / 690 Bar (material dependent). Two-hole pressure retaining covers are deployed for coupon locations, equipped with a pressure gauge and bleed port for assessment and maintenance. In cases of probe locations, three-hole pressure retaining covers additionally include a central hole for probe adaptor installation. For thread protection during transport and installation, lighter duty covers made of vinyl or carbon steel are also offered. Corr-defense highly recommends the use of Pressure Retaining Covers with all HP Access Fittings post-commissioning.



Sample part numbering

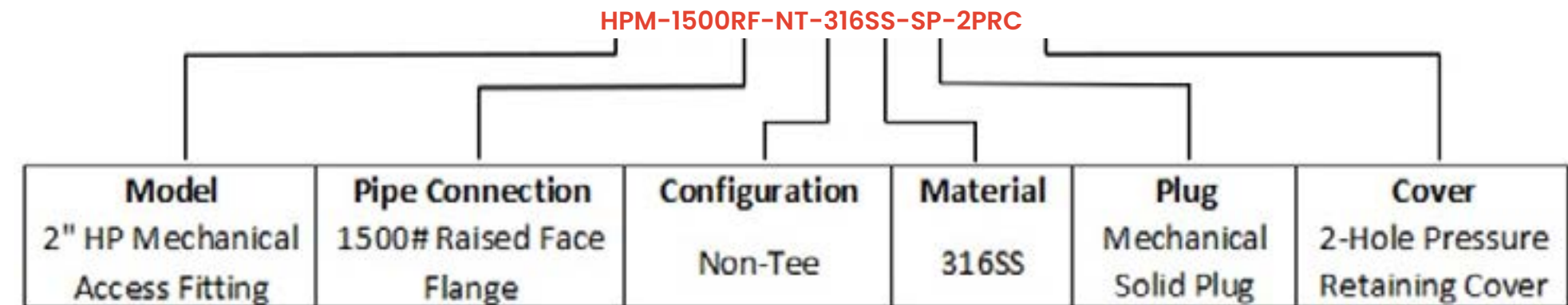

CD WEIGHT LOSS COUPONS

Selecting Weight Loss Coupons

Weight loss coupons are commonly secured onto a robust holder using a method that electrically isolates the coupon from its mount. These coupons can be mounted individually, in pairs, or in multiple pairs, depending on factors like process conditions, anticipated corrosion mechanisms, and the type of access fitting. The resulting outcomes can vary greatly depending on these factors, underscoring the importance of carefully selecting the appropriate combination. For expert guidance on choosing the best options, please contact a Corr-defense Specialist.

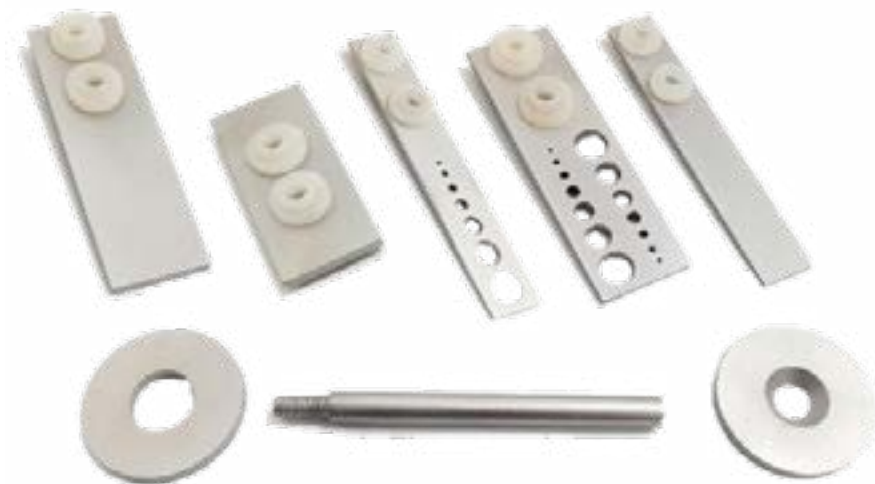

Coupon Configurations

Strip coupons are typically installed in pairs and positioned either within or partially within the process flow. Disc coupons, on the other hand, are usually flush-mounted to the wall of the pipe or vessel to closely replicate conditions at the process/containment interface. Scale coupons feature a strip-shaped design with variously sized holes, allowing for the evaluation of scaling tendencies. Weld coupons consist of sections of a weld, including heat-affected zones and parent metal, utilized to assess preferential weld corrosion. Stressed coupons are exposed to a predetermined amount of bending stress via a specialized mounting arrangement, enabling the evaluation of susceptibility to stress corrosion cracking.

Among these configurations, Strip and Disc types are the most commonly used. Coupons are provided cleaned, weighed, and serial numbered, then sealed in corrosion-inhibiting envelopes along with a set of insulators.

With various materials, dimensions, and finishes available, it's advisable to consult with a Corr-defense expert for both technical and commercial assistance.

Standard Oil & Gas Coupons

Materials	Dimensions
-1018 CS [UNS.G10180]	Strip [2-7/8" x 7/8" x 1/8"]
-API 5L X52	Scale [2-7/8" x 7/8" x 1/8"]
-A333 GR6	Ladder [2" x 7/8" x 1/8"]
-A106 GRB	Flush Disc [1.25" x 1/8"]
-API 5L X60/X65/X70	Multi Disc [1.25" x 1/8"]
-QPSL2	6" Strip [6" x 7/8" x 1/8"]
-2205	Retractable Strip [3" x 1/2" x 1/16"]
-S31803	Retractable Scale [3" x 1/2" x 1/16"]
-S355J2+N	
-L80-13C/L80-1	
-316(L)/304(L)	

*LPR Probe Electrodes & Bio-film Elements are also available - [contact info@corr-defense.us](mailto:info@corr-defense.us) for options.

Standard Laboratory & Water treatment Coupons

Materials	Dimensions
Aluminum 6063	[25 x 15]
Arsenical Brass C46500	[50 x 25]
316Ti	[76.2 x 12.7]
317L	
4130	
431	
17-4PH	
S31254 6Mo	
904L	
Nickel Alloy B3	
Inconel's	
Hastelloy's	
Alloy 925	
L80-9Cr	
L80 Super 13Cr	
API 5L X42	
A335 P9	
A335 P5	

* The Materials and Dimensions listed are the most common and readily available. Many other configurations are available and so please submit materials and dimensions for the best pricing & delivery options - info@corr-defense.us



Standard Oil & Gas Coupons



Standard Laboratory & Water treatment Coupons

Sample Part Numbering:

STRIP-2.875X0.875X0.125-G10180-A-A-A

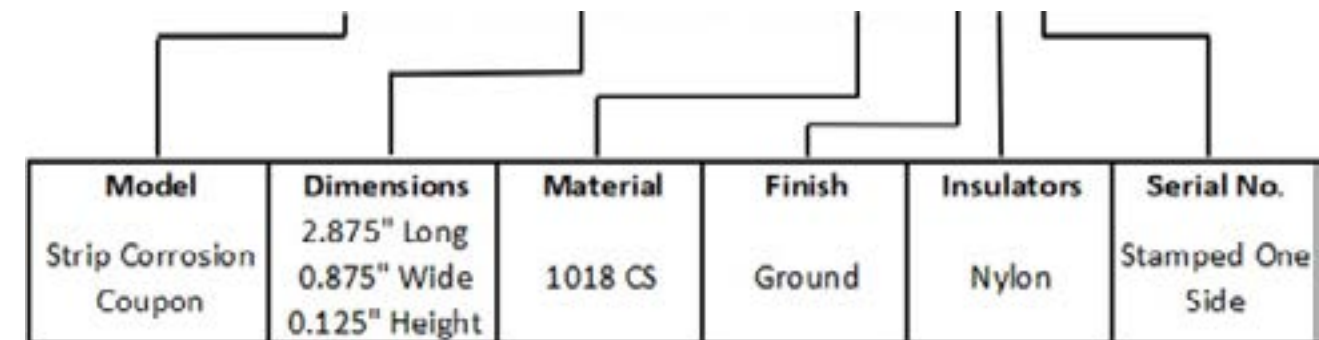

CDLP Retractable Corrosion Coupon Holders

Retractable Corrosion Coupon Holders

Ensuring corrosion control is essential for protecting critical assets and preventing costly damage. One effective method for monitoring facilities involves the use of corrosion coupons, which are inserted into the process system and periodically inspected for weight loss and visual analysis.

The Corr-defense CDLP series of coupon holders facilitates the insertion and removal of corrosion coupons in pressurized piping systems up to 1,500 psi / 103 bar. These holders are connected to permanently mounted full port valves, allowing operators to install or remove them without needing to isolate process pressure, thereby averting expensive shutdowns.

Available for flat strip, flush, and rod corrosion coupon types, holders come in standard lengths of 18", 24", 36", and 48", with longer lengths available upon

request. Crafted from 316SS materials with PTFE seals, holders ensure durability, though alternative materials can be accommodated upon request.

Key features

- High temperature (1000°f) option available.
- Meets NACE MR1075 & MR0103
- Low-cost monitoring option
- Easy installation and maintenance
- Provides average weight loss data
- Physical specimen to identify corrosion type
- ¾" to 1-½" access ports and devices available

Sample Part Numbering:

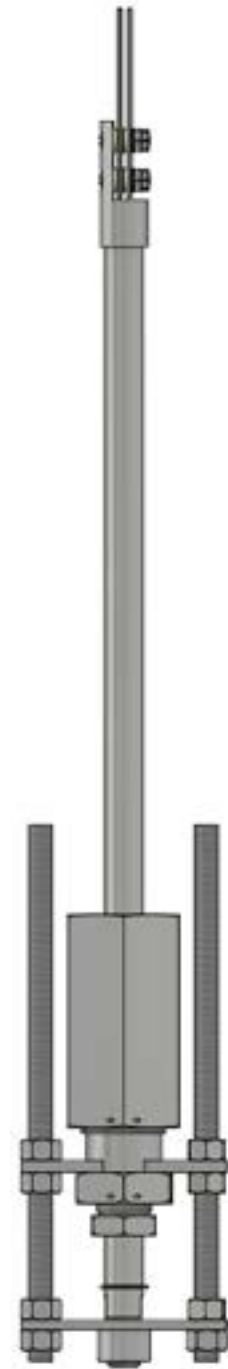
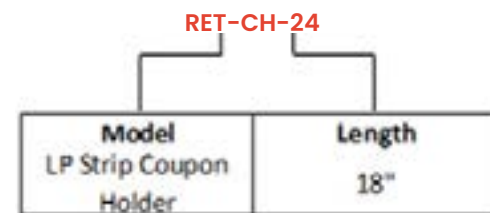

Pressure ratings up to 1,500 psi (103 bar)
Temperature Ratings up to +260 °C (+500 °F)

CD Retrieval Tools and Service Valves

Telescoping, Non Telescoping and Hydraulic Retrieval Tools with Single and Double Block and bleed service valves

Corr Defense presents a retrieval system featuring a retriever and service valve, designed for the safe and efficient insertion and extraction of probes, coupons, sensors, and chemical injection assemblies from a process, even under full pressure conditions.

Telescoping, Non Telescoping and Hydraulic Retrieval Tool options in 14, 18, 25 and 36 inch lengths. Longer lengths available and must enquire direct with Corr Defense. All Retrieval tools available for 3600 and 6000 PSI.

Sealing within the unit is achieved with Viton O-rings and graphite impregnated Teflon dynamic seals, ensuring optimal performance and durability. Corr Defense offers comprehensive training on the maintenance and operation of both the Retrieval Tool and Service Valve. Seal kits and repair kits available for all valves and Retrieval tools. Retrieval tool barrel chrome repair service available.

For further information regarding P/N's and pricing please contact us at info@corr-defense.us

**OPERATING PRESSURE UP TO
6000 PSI / 413 BARG**

**TEMPERATURE UP TO 230 °C /
446 °F**

**MODULAR DESIGN ALLOWS
CONVERSION FROM SINGLE TO
DOUBLE**

**SHORTEST & LIGHTEST VALVES
IN THE INDUSTRY**

**ROTATING BASE FOR EASIER
OPERATION**



HP Retrievable Corrosion Coupon Holders

CD-HP Series

For use with the AXHP Access Systems

Corrosion Coupon Holders

Controlling corrosion is crucial for preserving the integrity of essential assets, as it can incur substantial costs if left unchecked. One of the simplest and effective methods to monitor corrosion within your facility is through the use of corrosion coupons. These coupons are inserted into the process system and periodically retrieved for weight loss and visual analysis.

The Corr-defense CDHP range of coupon holders are specifically designed to work seamlessly with our CDHP access systems, facilitating the hassle-free insertion and removal of corrosion coupons in pressurized piping systems, even up to 10,000 psi. These holders are integrated through permanently mounted access fittings, enabling the installation and replacement of coupons without the need to isolate process



pressure, thereby averting costly shutdowns.

Standard coupon holders are crafted from 316SS material, with lengths tailored to suit the specific monitoring location.

Two primary styles of coupon holders are available: the 3" strip and flush disc. Strip coupon holders are ideal for monitoring at predetermined areas within the pipe, whereas flush disc coupon holders are well-suited for monitoring in line with the pipe wall. Additionally, we offer other coupon holder types, such as ladder coupons and multidisc, catering to specialized monitoring needs within multiphase lines.

Key Features

- Meet NACE MR0175 & MR0103 Standards
- Low-cost monitoring option
- Easy installation and maintenance
- Provides average weight loss data
- Physical specimen to identify corrosion mechanisms

HP Retrievable Corrosion Coupon Holders

Coupon Holder Sizing

Once you've determined the access fitting type and pipe dimensions, you can choose the style of holder and the desired location for the coupons. The following formulas can then be applied to position the coupons accurately within the line.

Refer to the formulas below to calculate the holder length. If the calculated length does not result in an even 0.25" increment, choose the next shortest length to the nearest 0.25".

Top of the Line Monitoring:

Coupon holder positions the effective length of coupon into pipe vessel. $(A + Pw + Wg) - 2.5"$

Where:

A = Length of Access fitting body
 Pw = Pipe wall (wall thickness of pipe)
 Pd = Pipe diameter (outside diameter of pipe)
 EI = Effective length of coupon (the portion of the coupon exposed to the environment, i.e. 3" coupon = 1-5/8", 6" coupon = 4-3/4")
 Wg = Weld gap (per weld procedures, 1/16" is normal per ANSI B31.1 1973)

Bottom of the Line Monitoring:

Coupon holder positions 1/2 of the coupon on either side of pipe centerline. $(A + 1/2Pd + Wg) - (2.5" + 1/2EI)$

Sample Part Numbering:

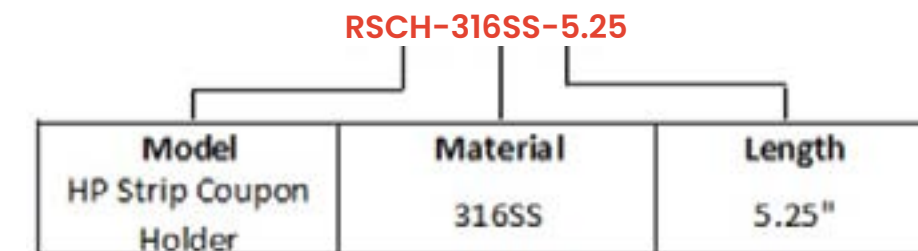

CORROSION UNDER INSULATION (CUI)

High Resolution Multifunction

The CUI sensors accurately measure relative humidity and temperature, wirelessly transmitting the data to the nearest Gateway. From there, the Gateway sends the measurements to the cloud and Site Monitoring Software. Featuring a compact and lightweight EX-d enclosure, the Gateway simplifies installation and offers additional connectivity options to the INVENIO Cloud. Both Wi-Fi and cabled connections (Ethernet or serial) are supported when

4G coverage is unavailable. To enhance resilience, the GW-1 is equipped with an internal rechargeable backup battery and increased buffering capabilities, ensuring the safe storage of sensor data during potential power outages.

Pre-analyzed data: This solution includes advanced streaming analysis of the data, providing a comprehensive visualization of the current and historical water wetting state. Users gain insights into the overall condition of the asset, identifying areas of concern and delving into affected parts and durations. This allows users to focus more

on risk assessment and less on interpreting raw sensor data.

Responsive aggregations: Time-based aggregations ensure a responsive user interface (UI), enabling users to quickly review extensive timeframes. Built-in statistical analysis further enhances the displayed data.

Real-time data: Data becomes available for visualization within seconds of transmission from the sensor.

ATEX AND IECEX INTRINSICALLY SAFE ZONE 0, GAS GROUP IIC, TEMP CLASS T4

WATER AND FROST PROOF -20 °C TO 100 °C

WIRELESS 915MHZ COMMUNICATION TO GATEWAY

SENSOR DATA SENT TO CENTRAL DASHBOARD VIA GSM/WIFI

SENSOR BATTERY CELL MINIMUM 10 YEAR LIFE @ 1-HOUR INTERVALS



TECHNICAL DATA

Type	CUI (Corrosion Under Insulation) Sensor
Radio Frequency	915 MHZ
Temperature	-20° to 100° C (-4° to + 212° F)
Temperature Sensor	Integrated
Typical RH Measurement Accuracy	± 2%
Typical Temperature Accuracy	± 0.2°C
Lifetime	Min. 10 years @ 1-hour interval (non extreme climatic conditions)
Power	Battery Cell
Dimensions	36 x 20 mm
Weight	20 g
Radio Cryptography	AES-128
Ex Rating	ATEX intrinsically safe, zone 0, gas group IIC, Temp Class T4
Radio Protocol	Proprietary

TECHNICAL DATA

Type	Gateway
Radio Frequency	915 MHZ
Temperature	-40° to 60° C (-40° to + 140° F)
Temperature Sensor	Aluminium (optional AISI 316)
Typical RH Measurement Accuracy	85 VAZ to 264 VAC / 24 VDC PoE Backup battery in case of power outage
Typical Temperature Accuracy	2.9 kg (5.3 kg AISI 316)
Lifetime	Min. 10 years @ 1-hour interval (non extreme climatic conditions)
Power	AES-128
Dimensions	Proprietary
Weight	Cellular (4G with 2G fallback)
Radio Cryptography	Wi-Fi, Ethernet, RS-485
Ex Rating	ATEX flameproof/molded encapsulation with intrinsically safe antenna connection, Zone 1/0, gas group IIC, temp class T6
Radio Protocol	ATEX flameproof encapsulation, Zone 1, gas group IIC, temp class T5



PRODUCTS



Access Fitting and Strip Coupon Holder



Corrosion Coupons



Datalogger



Beacon



ER Probe



Retractor Tool and Water Rack



Injection access Fittings



Transmitter



Retriever and service valve system